



Manufactured by
Apeks Marine Equipment Ltd.
Neptune Way, Blackburn,
Lancashire BB1 2BT England
www.apeks.co.uk



Copyright Notice

This owner's manual is copyrighted, all rights reserved. It may not, in whole or in part, be copied, photocopied, reproduced, translated, or reduced to any electronic medium or machine readable form without prior consent in writing from Apeks.

©2004 Apeks

Regulator Owner's Manual

Please read the instructions in this manual carefully before using your regulator.

Warnings, Cautions and Notes

Pay special attention to information provided in warnings, cautions, and notes, that is accompanied by these symbols:



A **WARNING** indicates a procedure or situation that, if not avoided, could result in serious injury or death to the user.



A **CAUTION** indicates any situation or technique that could cause damage to the product, and could subsequently result in injury to the user.





A **NOTE** is used to emphasise important points, tips, and reminders.





WARNING: This manual provides essential instructions for the proper setup, inspection, use, and care of your new regulator. Because Apeks regulators utilise patented technology, it is very important to take the time to read these instructions in order to understand and fully enjoy the features that are unique to your specific model. Improper use of your regulator could result in serious injury or death.

REGULATOR SERVICE RECORD

MODEL _____	DATE PURCHASED: _____
DATE SERVICED: _____	
SERVICED BY: _____	
PARTS CHANGED: _____	

DATE SERVICED: _____	
SERVICED BY: _____	
PARTS CHANGED: _____	

DATE SERVICED: _____	
SERVICED BY: _____	
PARTS CHANGED: _____	

DATE SERVICED: _____	
SERVICED BY: _____	
PARTS CHANGED: _____	

DATE SERVICED: _____	
SERVICED BY: _____	
PARTS CHANGED: _____	

NOTES

Apeks Warranty Registration

**NB: THIS REGISTRATION SHOULD BE RETURNED TO US
WITHIN 30 DAYS TO VALIDATE YOUR GUARANTEE**

Its purpose is to enable us to contact you in the unlikely event of any technical changes affecting the performance or safety of your purchase

Product purchased Serial Number(if applicable)
Serial Number(if applicable)

Date of Purchase..... Place of Purchase..... Price.....

What was your previous octopus (if applicable) Make Model

How long have you been diving? 0-1 years 1-3 years 4+ years

Average number of dives per year? 0-10 11-25 26-50 36-50 51-100 100+

Average length of dive? 0-½ Hour ½-1 Hour 1-2 Hours 2+ hours

Occupation:

Age: under 18 19-24 25-35 36-45 46-55 55+

Which diving disciplines have you tried? Open water scuba Technical Diving

Free Diving Cave Diving Commercial Diving

Membership/qualifying agency: e.g. BSAC, PADI, SAA etc

What do you like to do underwater? Observe marine life Wreck diving

Take photographs/Video Explore uncharted territory Research

Marine conservation Underwater archaeology

What do you think were the main influences on your Apeks purchase?

Quality Advertisements

Performance Product Design

Recommendation Magazine review/Article

Price Instructor

Value for Money Shop personnel/Dealer

Lifetime Guarantee Internet

Apeks reputation Other (please state)

Name (Mr/Mrs/Miss/Ms):

Address

Town/City Country Post Code

Tel No: Fax No:

Email:

NOTES

IMPORTANT-
YOU MUST RETURN THE FORM OVERLEAF WITHIN 30
DAYS OF PURCHASE TO VALIDATE YOUR GUARANTEE.

Return form to:-
APEKS MARINE EQUIPMENT LTD
Neptune way
Blackburn
Lancashire
BB1 2BT
U.K.

Returning Your Regulator For Service

Whenever your regulator requires annual service or warranty consideration, Apeks requires that you bring it or send it to an authorised Apeks dealer. It is important that you provide the dealer with a copy of your sales receipt and your Annual Service & Inspection Record located in the back of this booklet. For help in finding a dealer in your area, please contact your local distributor. Your distributor details can be found on our website www.apeks.co.uk

Contents

General Precautions & Warnings	4
Introduction	5
Using Enriched Air Nitrox (EAN)	6
Overview of Features	8
External Second Stage Adjustments	8
Integrated Venturi System	8
Inhalation Resistance Control Knob	9
First Stage Environmental Protection	10
Second Stage Cold Water Protection	10
Preparation and Setup	11
Attaching the First Stage to the Cylinder Valve (Yoke)	11
Attaching the First Stage to the Cylinder Valve (DIN)	13
DIN to Yoke Converter	15
Diving with Your Regulator	16
Pre-Dive Inspection Checklist	16
During the Dive.....	17
Diving In Cold Water	18
After the Dive	20
Removal of the Regulator from the Cylinder Valve (Yoke)	20
Removal of the Regulator from the Cylinder Valve (DIN)	20
Care & Maintenance.	21
Dealer Service & Repair	23
Warranty Information	24
Annual Service & Inspection Record	27

General Precautions & Warnings

- Before using this regulator, you must receive instruction and certification in SCUBA diving from a recognised training agency. **Use of SCUBA equipment by uncertified or untrained persons is dangerous and can result in injury or death.**
- This regulator is not configured for commercial use with surface supplied air.
- Always pressurise the regulator gradually by opening the cylinder valve SLOWLY.
- NEVER apply any type of lubricant to any part of the regulator or cylinder valve.
- DO NOT apply any type of aerosol spray to the regulator. Doing so may cause permanent damage to certain plastic components, including the second stage housing.
- Factory prescribed service for this regulator must be performed at least once annually by a factory trained Apeks service technician who is employed by an authorised dealer. Disassembly, repair, or first stage adjustment must not be attempted by persons who are not factory trained and authorised by Apeks.
- DO NOT leave a cylinder standing unsecured with the regulator attached to the valve. Doing so may cause permanent damage to the regulator and cylinder valve if the cylinder falls over.
- DO NOT carry SCUBA by the first stage when it is connected to a cylinder. Always carry the cylinder by the cylinder valve or an attached carrying device.
- When diving in cold water (below 10°C, or 50°F), you must have received training and certification in the techniques of cold water diving from a recognised training agency.



WARNING: It is dangerous for untrained and uncertified persons to use the equipment covered by this warranty. Therefore, use of this equipment by an untrained person renders any and all warranties null and void. Use of SCUBA equipment by anyone who is not a trained or certified diver, or receiving training under the supervision of an instructor, could lead to serious injury or death.

This warranty gives you specific legal rights. You may have rights which vary from country to country.

APEKS DISCLAIMS AND EXCLUDES ANY LIABILITY FOR INCIDENTAL OR CONSEQUENTIAL DAMAGES. SOME STATES IN THE U.S. AND CERTAIN OTHER COUNTRIES DO NOT ALLOW EXCLUSIONS OR LIMITATIONS OF LIABILITY FOR INCIDENTAL OR CONSEQUENTIAL DAMAGES, SO THIS MAY NOT APPLY TO YOU.

Restrictions

The following restrictions apply to this warranty:

1. This warranty does not cover normal wear. Factory prescribed service by an authorised dealer is required at least once annually.
2. This warranty does not extend to damages caused by improper use, improper maintenance, neglect, unauthorised repairs, modifications, accidents, fire, or casualty.
3. Cosmetic damage, such as scratches, dents, and nicks are not covered by this warranty.
4. This warranty does not extend to equipment used for rental, commercial, or military purposes.

4. DO NOT attempt to perform any disassembly or service of your regulator. Doing so may cause the regulator to malfunction, and will render the Apeks warranty null and void. All service must be performed by an authorised dealer.

OBTAIN SERVICE FOR YOUR REGULATOR AT LEAST ONCE A YEAR, FROM AN AUTHORISED DEALER. YOUR PERSONAL SAFETY AND THE MECHANICAL INTEGRITY OF YOUR REGULATOR MAY DEPEND ON IT.

WARRANTY INFORMATION

All warranty transactions must be accompanied by proof of original purchase from an authorised dealer. Be sure to save your sales receipt, and present it whenever returning your regulator for warranty service.

Limited Lifetime Warranty

Apeks warrants to the original purchaser that the product will remain free from defects in material and workmanship throughout its useful life; provided that it receives normal use, proper care, and prescribed dealer service subject to those restrictions stated below.

This warranty does not apply to units subjected to misuse, abuse, neglect, modification, or unauthorised service.

This limited warranty is extended only to the original purchaser for products purchased directly from an authorised dealer, and is not transferable.

This warranty is limited to repair or replacement only at the discretion of Apeks.

INTRODUCTION

Congratulations—and thank you—for choosing Apeks. All Apeks regulators have been designed and manufactured with pride, according to standards which meet or surpass all requirements for the BS EN ISO 9001:2000 quality control system.

Your Apeks regulator is covered by Apeks' Limited Lifetime Warranty against defects in materials or workmanship. This warranty is only extended to the original purchaser, and is not transferable. For more information, be sure to read the warranty section of this manual, and remember to save your sales receipts. Copies of these receipts must be presented whenever obtaining warranty service.

Perhaps more than any other piece of diving equipment you will own, your regulator's function and performance relies greatly on the care and maintenance it will receive, in addition to regularly scheduled dealer service. Before you dive with your new Apeks regulator, it is therefore important to read this manual in its entirety to become familiar with its features, as well as the correct procedures for setup, pre-dive inspection, and post-dive maintenance.

Please read on to learn how you can obtain the maximum enjoyment from your regulator, and maintain its like-new performance for many years to come.



WARNING: Improper use or misuse of SCUBA equipment may result in serious injury or death. Read and understand this owner's manual completely before diving with your Apeks regulator.





NOTE: This product has been examined by Germanischer Lloyd AG, Vorsetzen 32, D-20459 Hamburg, Germany, notified body for PPE Identification number 0098.



NOTE: This product meets the requirements as laid out in the directive relating to Personal Protective Equipment, Council Directive 89/686/EEC modified by Council Directive 86/58/EC.

USING ENRICHED AIR NITROX (EAN)

 **WARNING:** This section of your owner's manual contains important information regarding the use of your equipment with enriched air (EAN / Nitrox). Do not attempt to use this product with enriched air until you have read and understand this section of the manual. To do otherwise increases your risk of injury or death.

 **WARNING:** Obtain an EAN (Nitrox) Certification. In order to enjoy the special benefits that EAN/nitrox can provide, it is extremely important to obtain special training from a nationally recognised training agency in addition to that which is provided for openwater SCUBA.

Your Apeks regulator has been prepared for use with Enriched Air Nitrox (EAN) where the percentage of oxygen in the EAN does not exceed 40%. This is possible because each regulator is built to a high standard of cleanliness using EAN compatible components and lubricants. In addition, each regulator design has passed stringent adiabatic compression testing to ensure its safety and compatibility with increased percentages of oxygen.

If it is your intention to use your new Apeks regulator with EAN (O₂ not to exceed 40%), it is imperative that you maintain the internal cleanliness of the regulator (see section on Care and Maintenance, page 21). If it is your intent to use the regulator interchangeably with breathing air, the breathing air should be oxygen-compatible or "hyperfiltered" whereas the condensed hydrocarbons do not exceed 0.1 mg/m³. Your local authorised Apeks dealer can help you determine whether the breathing air that they provide meets this criterion.

Standard compressed breathing air, often referred to as Grade E, does not necessarily meet this criterion. Grade E breathing air may contain a certain level of hydrocarbons, including traces of compressor oils that while not considered harmful to breathe, can pose a risk in the presence of elevated oxygen content. Passing hydrocarbons

- Adjustable models should be stored with the inhalation control knob turned all the way out (anti-clockwise), away from the regulator body. This will help to extend the life of the low pressure seat.
- When the regulator is completely dry, store it in a clean box or sealed inside a plastic bag. Do not store it where it may be exposed to extreme heat or an electric motor which produces ozone. Prolonged exposure to extreme heat, ozone, chlorine, and ultraviolet rays can cause premature degradation of rubber parts and components.
- Never store the regulator while it is connected to the cylinder valve.
- Do not use any type of solvent or petroleum based substances to clean or lubricate any part of the regulator. Do not expose any part of the regulator to aerosol spray, as some aerosol propellants attack or degrade rubber and plastic materials.

Dealer Service & Repair

- It cannot be assumed that a regulator is in good working order on the basis that it has received little use since it was last serviced. Remember that prolonged or improper storage can still result in internal corrosion and/or deterioration of O-ring seals.
- You must obtain factory prescribed service for your regulator at least once a year from an authorised dealer, regardless of the amount of use it has received. Your regulator may require this service more frequently, depending on the amount of use it receives and the environmental conditions in which it is used.
- If the regulator is used for rental or training purposes, it will require complete overhaul and factory prescribed service every three to six months or 50 hours continual use. Chlorinated swimming pool water is an especially damaging environment for SCUBA equipment, due to the high levels of chlorine and pH balancing chemicals which cause certain components to rapidly deteriorate.

- b. If it is not feasible to soak the regulator while it is attached to a cylinder, it may be soaked unpressurised – provided that the dust cap is securely sealed over the inlet, and the second stage purge buttons are not depressed while the regulator is submerged or wet.



NOTE: When soaking or rinsing an adjustable model regulator unpressurised, check to ensure that the second stage inhalation control knob is turned completely “in” (clockwise) to prevent moisture from entering the valve and LP hose.



CAUTION: DO NOT loosen the first stage yoke screw, depress the second stage purge button, or turn out the inhalation control knob (if present) if the regulator is submerged unpressurised. Doing so will allow the entrance of moisture, and will require that the regulator be returned to an authorised dealer for service.

4. While the regulator is soaking, move the IVS control switch (if present) back and forth several times from the “MIN” (–) to the “MAX” (+) settings. You may also turn the inhalation control knob slightly back and forth—no more than 4 turns. This action will help to loosen any salt or mineral deposits that may remain lodged in the second stage.
5. After the regulator has been properly soaked, it is important to rinse it vigorously by flushing the first stage ambient chamber (non-environmentally sealed models only), the second stage mouthpiece, and the openings in the second stage front cover with a pressurised stream of water. This will remove any deposits of salt and minerals that were loosened during soaking. If the regulator is not pressurised, do not press the purge button underwater. Moisture may otherwise enter the valves, which will require that the regulator be returned to an authorised dealer for service.
6. Wipe the regulator as dry as possible and hang by the first stage to ensure that all remaining moisture drains from the second stages.

through a valve and regulator creates a cumulative effect where the hydrocarbons build up over time along the internal passageways of the equipment. When these hydrocarbons come in contact with high-pressure oxygen enriched air, they can pose a very real hazard that can lead to combustion.

Therefore, if a regulator has had use with Grade E breathing air, it should be returned to an authorised Apeks dealer for overhaul service including hydrocarbon cleaning, prior to being put back into nitrox service.

If a regulator is to be used with EAN gas mixes over 40% then it must be professionally converted to oxygen service.

Although second stage components are not exposed to high pressure EAN, Apeks recommends that the same cleaning procedures be followed for the complete regulator. This prevents the possibility of cross contamination and guarantees the cleanliness of the entire regulator.



NOTE: Apeks offers additional models and kits that are designed and manufactured for use with enriched air nitrox where the percentage of oxygen exceeds 40%. For information about these models, consult your authorised Apeks dealer.



NOTE: In some countries the rules and regulations relating to Nitrox use differ. Please contact your local distributor for details.

OVERVIEW OF FEATURES

The Apeks family of regulators consists of different models which satisfy a wide range of diving interests; from entry level sport diving, to advanced diving in more demanding and extreme conditions. By now, your authorised dealer has already explained to you the specific features that your particular model offers, and you have made your purchase after comparing the benefits of these features to your personal diving needs and interests. Be sure to review this section to learn more about your model's features and how to obtain the maximum benefit from using them.

External Second Stage Adjustments

External adjustment features offer many advantages, including the ability to adjust your second stage regulator's sensitivity as your diving conditions change. This can allow you to maintain peak performance throughout every dive, or to desensitise your regulator's opening effort at times when you are not breathing from it.

Integrated Venturi System

All Apeks second stages are equipped with a unique integrated venturi system (IVS) control switch. The IVS switch, located on the opposite side to the hose connection of the second stage, controls the venturi assist to reduce sensitivity to freeflow at the surface and provide maximum airflow at depth.

Whilst diving set the switch to plus (+) to achieve maximum venturi assistance for easier breathing.

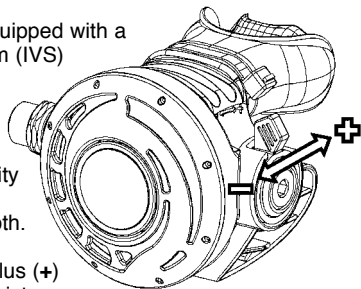

CAUTION: Be careful when removing the first stage from the cylinder valve to ensure that moisture does not enter either the inlet opening of the first stage or the opening of the DIN valve.

5. With the cylinder valve facing away from you, open the valve slightly to release a short burst of air, and then immediately close the valve. This will clear any moisture that may have entered the valve opening. Immediately seal the protector cap securely in place over the opening of the DIN valve to prevent the entrance of moisture or debris.

Care & Maintenance

It is important to provide the proper preventative maintenance in order to ensure the best possible performance and maximum life of your Apeks Regulator. The following maintenance procedures should be performed routinely after each use to ensure that the regulator is cleaned, inspected, and prepared for the next use or for storage.

1. Whenever the regulator is removed from the cylinder valve, it is important to wipe or blow the dust cap completely dry, and then fasten it securely over the first stage inlet fitting. This is critical to prevent the entrance of moisture into the first stage.
2. As soon as possible after diving, the regulator should be rinsed thoroughly with fresh water while it is attached to a cylinder and pressurised with air.
3. Rinsing alone, however, will not sufficiently clean the regulator. To clean the regulator as thoroughly as possible, it is necessary to soak it in warm (not over 50°C / 120°F) fresh tap water for at least one hour.
 - a. The preferred method is to attach the regulator to a charged SCUBA cylinder, open the cylinder valve to pressurise the regulator, and thoroughly soak both the first and second stages. Pressurising the regulator will effectively prevent the entrance of moisture and/or contaminants into the regulator while it soaks.

AFTER THE DIVE

 NOTE: Rinse your regulator completely in fresh water before depressurising it, and thoroughly dry the first stage and cylinder valve. This will help to prevent any contaminants from entering the regulator when it is removed from the cylinder.

Removing the Regulator from the Cylinder Valve (Yoke Connector)

1. Shut off the cylinder air supply by turning the cylinder valve hand-wheel clockwise until it stops.
2. While observing the submersible pressure gauge, depress the purge button of the second stage. When the gauge reads zero and airflow cannot be heard from the second stage, release the purge button.
3. Turn the yoke screw anti-clockwise to loosen and remove the first stage from the cylinder valve.
4. Dry the dust cap with a clean towel, or with low pressure air.
5. Place the dust cap over the first stage inlet fitting and seal it securely in place by tightening down the yoke screw.

Removing the Regulator from the Cylinder Valve (DIN Connector)

1. Turn off the cylinder air supply by turning the cylinder valve hand-wheel clockwise until it stops.
2. While observing the submersible pressure gauge, depress the purge button of the second stage. When the gauge reads zero and airflow cannot be heard from the second stage, release the purge button.
3. Turn the first stage handwheel anti-clockwise to loosen and remove the first stage from the cylinder valve.
4. Blow out any water inside the protector cap or wipe it out with a soft cloth, and wipe the threads of the first stage connector clean and dry. Install the cap over the threads of the first stage connector.

To prevent the second stage from free-flowing, however, you should set the IVS to the MIN(-) setting during entry or while swimming on the surface.

Inhalation Resistance Control Knob

Some second stage models are equipped with an additional adjustment, which controls inhalation resistance.

This control knob, located beside the IVS switch, adjusts the amount of effort required to start the air flow at the beginning of the inhalation cycle. As it is turned "in" (clockwise), the opening effort will increase. This will make the second stage less sensitive to sudden changes in ambient pressure. Turning the knob "out" (anti-clockwise) will decrease the opening effort to make breathing easier.

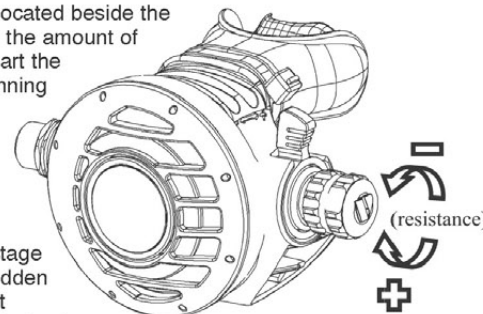

This adjustment is particularly useful at deeper depths, or in variable conditions that affect the opening effort of the second stage, such as strong currents or while using a diver propulsion vehicle (DPV). You can use the inhalation control knob to tune your regulator to maintain its peak performance throughout the course of your dive, or you can leave it set in its mid-range position and dive with it as you would any non-adjustable second stage.

For more information on using these adjustments, refer to the section titled, [Diving With Your Regulator](#), on page 16.

First Stage Environmental Protection

For diving in contaminated or cold water conditions, some Apeks first stages feature a unique "DRY" environmental sealing system which completely eliminates the need for messy silicone oil or grease filling. An external diaphragm seals the ambient chamber from the surrounding sea water, while a specially designed piston transfers ambient water pressure to the internal diaphragm.



This helps to prevent ice from forming inside the ambient chamber, and also extends the life of the first stage internal diaphragm. It is important to remember, however, that this environmental protection will not completely prevent the second stage from icing or freezing.

Second Stage Cold Water Protection

With the exception of the AT20 & T20, Apeks second stages incorporate a thermo-dynamic heat exchanger at the second stage hose fitting. This patented (Patent No. U.S. Pat. 5,265,596) feature is designed to draw in the surrounding water temperature, thereby warming the valve mechanism and greatly reducing the possibility of second stage freeze-up.

For important information about diving in cold water, refer to the section titled, Diving in Cold Water, on page 18.

It is possible for icing or freeze-up to occur, even with a regulator that has been specially designed for cold water use. It is therefore imperative to practice the correct cold water diving procedures, and take special precautions to prevent second stage icing. This training must include procedures for dealing with regulator freeze-up, unexpected freeflow, and emergency out-of-air situations. These procedures are taught in cold water training programs provided by most recognised certification agencies.

The following measures will further reduce the risk of freeze-up:

1. Request verification from your dive store that the air in your cylinder(s) is dry. It should have a dew point below -54°C or -82°F. Excess water vapor can freeze, causing a freeflow condition, or blocking the flow of air entirely.
2. Protect your regulator from any contact with water until the moment that you are ready to begin your dive.
3. Protect your equipment from cold temperatures before the dive. Keep your regulator and all its accessories in a warm, dry place.
4. Avoid breathing through the regulator or pressing the purge button in very cold air before entering the water.
5. Avoid removing the regulator from your mouth during the dive. This will prevent cold water from entering the regulator's second stage.
6. As far as is possible, avoid heavy exertion during the dive in order to minimise the volume of air flowing through the regulator. Ensure the IVS lever is set to plus (+) position while diving. Avoid discharges of air on the surface. Do not continually press the purge button.
7. Do not practice buddy breathing etc. Keep your regulator in your mouth. In an emergency offer or take a spare regulator.



WARNING: SCUBA regulators and equipment have operational limits when used in water colder than 10°C (50°F). If you attempt to dive in cold water without first obtaining the necessary training and preparation of your equipment, you risk serious injury or death.

The second stage incorporates a deflector to minimise the effects of strong currents on the diaphragm, however, if you swim underwater in an upside down or sideways position, or facing a strong current, you can turn the inhalation control knob back "in" (clockwise), to desensitise the opening effort to prevent any freeflow.

At the end of your dive, be sure to return the IVS switch to the MIN (–) position, and turn the inhalation control knob "in" when you have arrived at the surface.

 **WARNING: Deep diving requires special training and equipment, and greatly increases your risk of decompression sickness and other serious diving injuries. If you attempt to dive beyond prescribed no-decompression limits without first obtaining sanctioned technical dive training, you risk serious injury and death.**

Diving In Cold Water

The C.E.N. standard defines cold water as 10°C (50°F) or lower. In such conditions, there is a risk of freeze-up; particularly in fresh water, which has a higher freezing point and more severe thermoclines. Incidents of first or second stage freeze-up usually result in freeflow from the second stage, resulting in a rapid loss of air.

Before attempting an unsupervised dive in cold water conditions, it is important for you and your buddy to obtain certified training in cold water diving techniques, and to use only equipment which has been specifically designed and maintained for such use. If these precautions are not taken, freeze-up can occur.

PREPARATION AND SETUP

Apeks recommends that you bring your regulator to your authorised dealer for the installation of any accessory items, including instrumentation, LP quick disconnect hoses, and alternate air source second stages. Your dealer can also answer any questions you may have pertaining to the information in this manual.

1. Check the second stage IVS control switch to ensure that it is set to the "MIN" (–) position prior to connecting your regulator to the tank.
2. If present, gently turn the inhalation control knob "in" (clockwise), only until it stops. Do not apply excessive pressure.
3. If you are using a cylinder with a yoke connection valve, check the cylinder valve O-ring is fitted and not worn or damaged. If you are using a high pressure cylinder with a DIN connection valve, remove the protector cap from the first stage to inspect the sealing O-ring of the DIN connector. If the sealing O-ring is damaged or worn, replace it before mounting the regulator on the cylinder valve.

Attaching the First Stage to a Cylinder Valve (Yoke Connection)

 **WARNING: OPEN VALVES SLOWLY TO AVOID OVER-PRESSURISATION. When pressurising your SCUBA system, be sure to open the cylinder valve slowly to minimise the generation of heat. Failure to do so, with Enriched Air Nitrox (EAN) present, increases the risk of combustion that can lead to serious injury or death.**

It is considered safe practice, especially when using EAN, to open the cylinder valve slowly and let the first stage pressurise slowly. Rapid pressurisation causes adiabatic compression of the breathing gas, which generates heat inside the first stage. Heat, along with elevated percentages of oxygen and an ignition source (from contamination) are the ingredients that can cause combustion. This is why it is

necessary to keep the interior of the regulator clean and the percentage of oxygen below 40% along with the slow opening of the cylinder valve (for regulators over 40% oxygen please see page 6).

To attach a yoke-style first stage to the cylinder valve, follow these steps:

1. Partially unscrew the yoke screw of the first stage regulator so that the dust cap can be removed from the air inlet.
2. With the cylinder valve facing away from you, release a small amount of air from the cylinder by turning the hand-wheel anti-clockwise to open the valve only slightly. When air is heard exiting, immediately close the valve. This will clear any moisture or debris that may be inside the cylinder valve outlet opening. Check the O-ring is still in place.
3. Place the first stage regulator over the cylinder valve so that the inlet fitting aligns with the O-ring of the cylinder valve, and the LP hose of the primary second stage will be routed over the desired shoulder. While holding the first stage in place, turn the yoke screw clockwise. Ensure that the yoke screw mates into the small dimple on the backside of the cylinder valve, and tighten finger-tight only - **do not over tighten**.
4. If a submersible pressure gauge is attached to the first stage, ensure that the gauge is facing away from you. Pressurise the regulator by slowly turning the cylinder valve handwheel anti-clockwise. Continue to turn the valve handwheel anti-clockwise until it is fully open, and then turn it back $\frac{1}{2}$ turn.

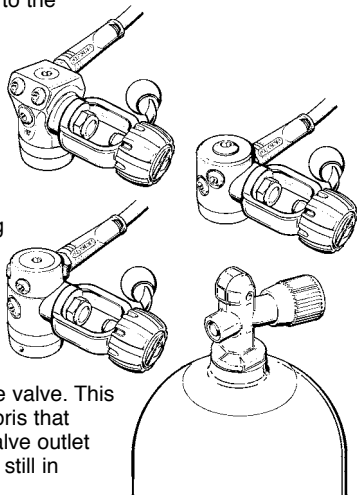

6. With the IVS lever set to (-) depress the purge button momentarily to blow out any dust or debris which may have entered the second stage. Release the purge button and listen to ensure that the second stage does not continue to flow any air after the purge button is released.
7. Inhale slowly and deeply from the regulator several times. The regulator must deliver enough air for you to breathe easily without noticeable resistance.
8. Check to ensure that the submersible pressure gauge is displaying an accurate measurement of the air pressure inside the cylinder.
9. Check to ensure that the IVS control switch is set to "MIN" (-). If present, gently turn the inhalation control knob completely "in" (clockwise), only until it stops. Do not apply excessive pressure. These settings will help to minimise any loss of your air supply during entry or while making a long surface swim. Adjustments can be made below the surface.

During the Dive When you are ready to submerge, place the second stage in your mouth and set the IVS switch in the plus (+) position. If present, turn the inhalation control knob out (anti-clockwise) until the regulator breathes comfortably without leaking or being undesirably sensitive.

As you descend, you may want to turn the inhalation control knob further out to make breathing easier. This will be particularly true on deep dives where the air density increases.

DIVING WITH YOUR REGULATOR

Before each use, it is important to perform a complete pre-dive inspection of your regulator. NEVER dive with a regulator that shows signs of damage or unsatisfactory performance until it has received complete inspection and service from an authorised dealer.

Pre-Dive Inspection Checklist:

1. Carefully inspect all hoses at their fittings to ensure they are securely connected into their respective ports on the first stage. Inspect the length of each hose to ensure that the hoses are not blistered, cut, or otherwise damaged. If hose protectors are present, slide the protectors back to expose the hose fittings, and inspect the hoses as described above.
2. Visually inspect both the first and second stage regulators for any signs of external damage.
3. **Environmentally sealed first stages only:** Closely inspect the external sealing diaphragm for any signs of damage or deterioration that may cause leakage. Check to ensure that the retainer which holds the external diaphragm in place is tightly secured.



WARNING: If the external diaphragm shows any signs of damage or neglect, DO NOT attempt to dive with the regulator until it has received factory prescribed service from an authorised dealer. The regulator's performance may be compromised, and first stage freeze-up could occur in cold water conditions.

4. Connect the first stage regulator to a fully charged SCUBA cylinder. (For mounting instructions, read the Setup section on pages 11-15.) SLOWLY open the cylinder valve to pressurise the regulator. Continue turning the valve anti-clockwise until it stops. This is to ensure that the valve is completely open.
5. If present, turn the inhalation control knob completely "out" (anti-clockwise), and then back "in" (clockwise) until the regulator provides maximum ease of breathing with no leakage present. Do not apply excessive pressure.

5. Listen near the first stage to check for any leakage. If leakage is detected, immerse the first stage and cylinder valve while pressurised to determine the source.
6. If leakage has been detected, follow the procedure for removing the regulator from the cylinder valve on page 20. If air was leaking between the first stage and cylinder valve, replace or re-seat the cylinder valve O-ring as needed and repeat the above procedure. If leakage persists, return the system to an authorised dealer.

Attaching the First Stage to a Cylinder Valve (DIN)



WARNING: OPEN VALVES SLOWLY TO AVOID OVER-PRESSURISATION. When pressurising your SCUBA system, be sure to open the cylinder valve slowly to minimise the generation of heat. Failure to do so, with Enriched Air Nitrox (EAN) present, increases the risk of combustion that can lead to serious injury or death.

It is considered safe practice, especially when using EAN, to open the cylinder valve slowly and let the first stage pressurise slowly. Rapid pressurisation causes adiabatic compression of the breathing gas, which generates heat inside the first stage. Heat, along with elevated percentages of oxygen and an ignition source (from contamination) are the ingredients that can cause combustion. This is why it is necessary to keep the interior of the regulator clean and the percentage of oxygen below 40% along with the slow opening of the valve.

To attach a DIN-style first stage to the cylinder valve, follow these steps:

1. Remove the protector cap from the cylinder valve, if fitted. With the cylinder valve facing away from you, release a small amount of air from the cylinder by turning the handwheel anti-clockwise to open the valve slightly. When air is heard exiting, immediately close the valve. This will clear any moisture or debris that may be inside the threaded cylinder valve opening.

2. Position the first stage near the cylinder valve so that the LP hose of the primary second stage will be routed over the desired shoulder. Thread the first stage DIN connector into the cylinder valve and tighten the handwheel by hand until it is lightly snug. DO NOT use tools to tighten.
3. If a submersible pressure gauge is attached to the first stage, ensure that the gauge is facing away from you. Pressurise the regulator by slowly opening the cylinder valve handwheel. Continue to turn the cylinder valve handwheel until fully open, and then back $\frac{1}{2}$ turn.
4. Listen near the first stage to check for any leakage. If leakage is detected, immerse the first stage while pressurised to determine the source.
5. If leakage has been detected, follow the procedure for removing the regulator from the cylinder valve on page 20. If air was leaking between the first stage and cylinder valve, replace or re-seat the cylinder valve O-ring as needed and repeat the above procedure. If leakage persists, return the cylinder and regulator to an authorised dealer.

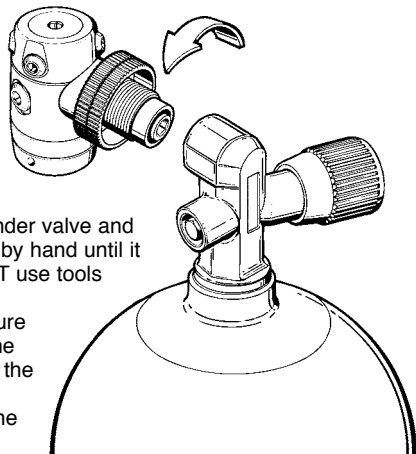

DIN to Yoke Converter

For regulators which may be used back and forth between Yoke and DIN connections, Apeks offers a convenient DIN to Yoke converter. First, obtain factory prescribed installation of the DIN connector through an authorised dealer. Then, simply attach the converter to connect your regulator to a yoke valve.

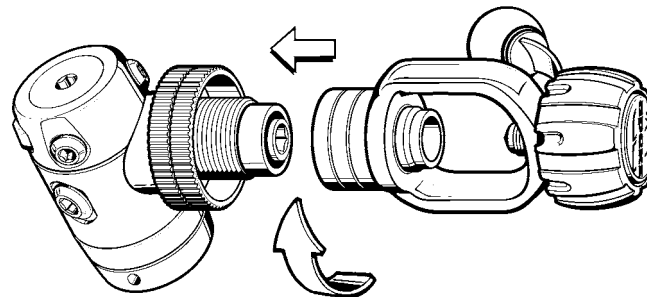

WARNING: Adaptors from yoke 1st stage to a DIN cylinder valve must never be used. This would allow a greater working pressure to be used than the yoke connector is designed to take.